

RELY ON EXCELLENCE

AGS agitator seals – For maximum product purity.

Designed for reactors, mixers, dryers and special machines



reliable



wear-free



economical

Gas-lubricated agitator seals: No chance of contamination

Gas-lubricated agitator seals are used to prevent contamination of the process medium with a barrier medium and frictional heating. This is achieved with a stable gas film between the sliding surfaces of the seal. Product contamination from abrasion can therefore not occur.

The AGS series by EagleBurgmann is the wear-free, hygienic seal solution for agitators used in pharmaceutical, chemical and food production.

Our product line includes double seals in cartridge design for

- Steel and glass-lined containers in DIN and non-DIN designs
- Shaft diameters from 20 to 260 millimeters
- Pressures up to 6 bar
- Useful within a temperature range of -20°C to $+250^{\circ}\text{C}$
- ATEX zone 0

Of course, customer-specific modifications are also possible. Simply contact us and our experts will be happy to assist you.



Diamond-like carbon: Sliding surface technology for all phases of operation

Diamond-like carbon (DLC) is a sliding ring coating made of carbon that possesses outstanding properties similar to those of diamond. Only a few micrometers thick, it combines extreme hardness, a minimal friction coefficient, outstanding corrosion resistance and excellent wear protection. The biocompatibility and chemical resistance of DLC make it even more attractive. All reasons why DLC sliding rings by EagleBurgmann have proven their worth for years in demanding applications in the chemical, pharmaceutical and food industry.



AGSZ and AGSR: Every need is covered



Clean and reliable

- No friction, no abrasion: The sliding parts of our AGS seals operate without touching. This makes it nearly impossible for the processed product to become contaminated.
- The minimal starting torque of the seals only generates a negligible amount of friction heat.
- Sealing liquid does not enter the product, and the process in the agitator tank is not impaired by the inert buffer gas (N₂).
- The position of the product-side counter ring of the AGSR allows easy cleaning of the sealing point.

Built to last

- The special clamping ring design for torque transmission decouples the seal from axial shaft movements.
- The special seal concept with a stationary sliding ring renders the AGSZ insensitive to tumbling or distortion by the agitator shaft.
- The DLC coating of the sliding ring improves operation in emergency situations.

Economical

- The ready-to-fit cartridge unit makes the seal easy to install and reliable in use.
- The special seal design reduces the number of wearing parts which greatly simplifies servicing and maintenance.
- Wear-free operation (lift-off) greatly extends the life of the seal.
- A simple gas supply system is adequate and gas consumption is minimal.

For sensitive production processes



Chemical industry



Pharmaceutical industry



Food and beverage industry

Run dry as if lubricated, wear-free and energy-saving

The standard: AGSZ



Clamping ring

- For transmitting torque
- Decouples the seal; enables large axial movements

Central rotating counter ring (AGSZ)

- Reliable, speed-independent lift-off
- The greater sliding surface width increases gas film stiffness
- Stabilizes operating behavior

Stationary sliding rings

- Prevents jamming
- Insensitive to tumbling movement
- No incorporation of dynamic O-ring
- DLC-coated for optimized protection in all operating phases

Constant form and function

The hard/hard material combination of the sliding parts is highly resistant to compression and ensures a constant sealing gap height.

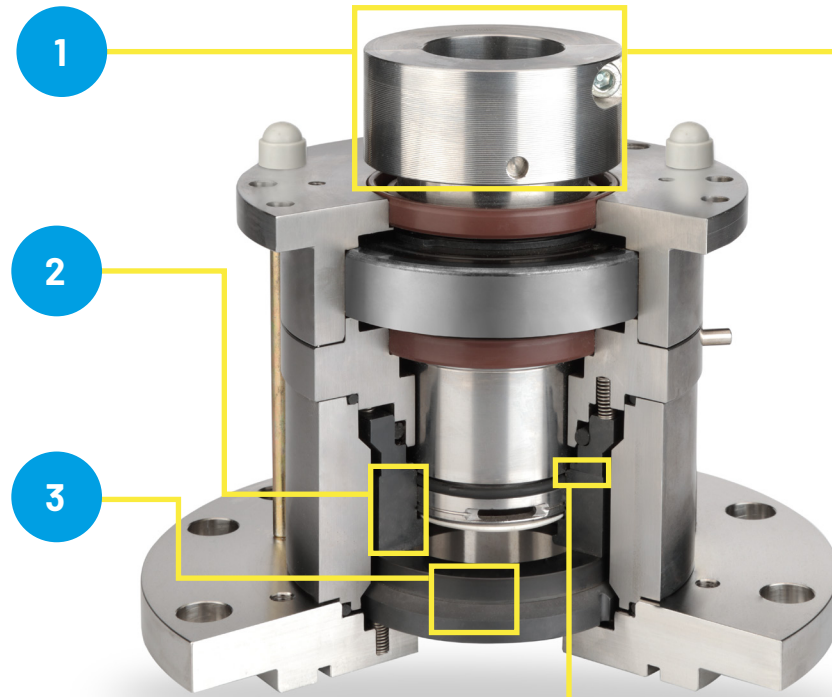

- Gas grooves**
- Low starting torque
 - Independent of direction of rotation
 - Contact-free operation from 3 bar differential pressure

For difficult media: AGSR

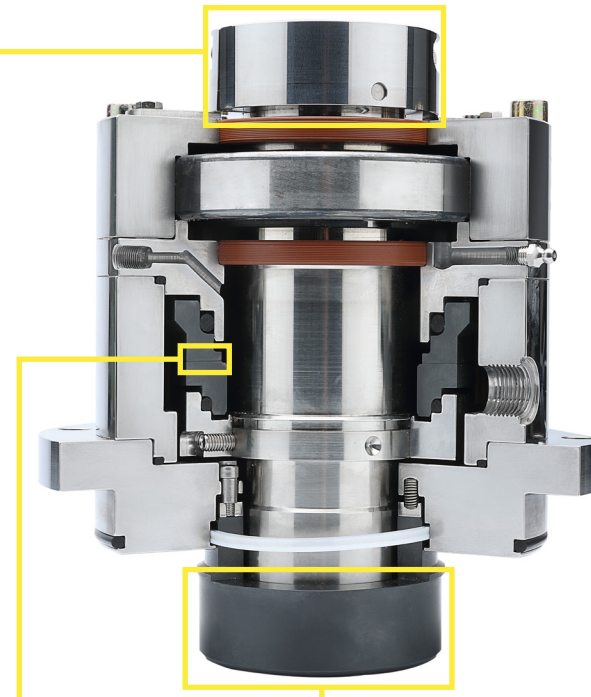

Product-side counter ring

- The minimal dead space and very smooth surface make cleaning easy
- Self-cleaning effect from rotating counter ring
- Highly robust
- Outstanding heat dissipation

U-gas grooves:

Reliable, rotational direction-independent operation
The gas grooves are designed so that the sliding parts lift off statically and run free of contact at a pressure differential of 3 bar. Dynamic movement is therefore unnecessary. A greater sliding surface width increases gas film stiffness and ensures consistent performance.



Designs

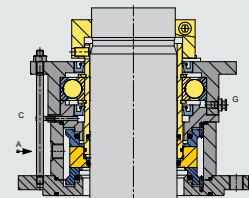

AGSZ481

- Basic version
- For DIN 28138-compliant steel containers
- Can be modified to fit the installation space (AGSZ451)

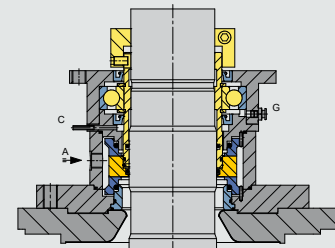

AGSZ461

- Metal-free design of product-contacting parts
- For DIN 28138-compliant glass-lined containers, parts 1+3
- Can be modified to fit the installation space (AGSZ491)

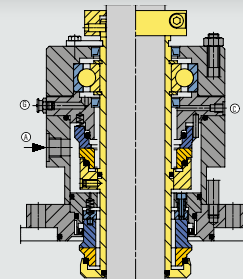

AGSR58

- Available bellows connection

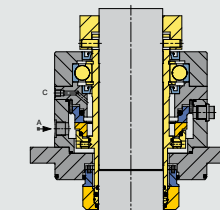

AGSR38

- Sterile design

Optional

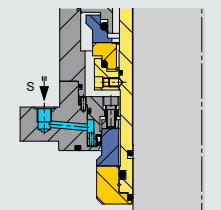

Flushing

- For side and bottom entry drive
- Increases process reliability

Convincing details

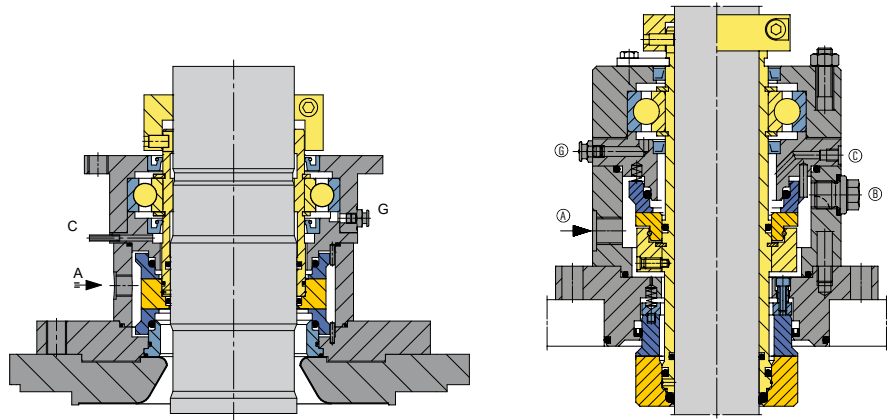

Product features	AGSZ	AGSR
Shaft diameter d1 [mm]	40 ... 220	20 ... 260
Max. pressure p1	6 (87) (higher pressures on request)	6 (87) (higher pressures on request)
Temperature t1 [°C]	-20 ... +200 (+250 with cooling flange)	-20 ... +200
Sliding velocity vg [m/s]	0 ... 5 (higher sliding velocity on request)	0 ... 5 (higher sliding velocity on request)
Top entry drive	•	•
Side/bottom entry drive	-	•
With bearing	•	•
Without bearing - on request	•	•
DIN	•	-
Non-DIN	•	•
Metal-free on product side - as option	•	•
CIP-/SIP-compatibility - Hygienic Design as option	Limited	•
ATEX zone 1,2	•	•
ATEX zone 0	•	-
FDA-compliant materials - as option	•	•
Sterile design - as option	-	•
Functional add-ons	Cooling flange/Heating flange, Flushing, Hygiene flange	Flushing, Connectivity for bellows

Materials

- Seal faces: Silicon carbide (SiC), DLC coated
- Seats: Silicon carbide (SiC)
- Elastomers: FKM, EPDM, FFKM
- Springs: 1.4571
- Housing parts, flange: 1.4404
- Parts in contact with product (AGSZ461/491): Aluminum Oxide

Efficient supply by barrier pressure system

AGSZ and AGSR agitator seals only require a simple barrier pressure system. The supply systems of the GSS series are specially designed for contact-free, gas-lubricated mechanical seals. The tailored design creates an optimum operating environment and ensures that the seals function reliably for a long time.



GSS4016

Operating range

- Medium: N₂ or air
- Sealing pressure: 0.5 – 10 bar (g)
- Buffer pressure: 3.5 – 13 bar (g)
- Operating temperature: -10°C to +55°C
- Minimum differential pressure: 3 bar (44 PSI)

Function

- Filter buffer gas
- Ensure constant buffer pressure
- Measure buffer gas flow
- Notification when the maximum permissible buffer gas flow is exceeded
- Notification when the buffer pressure drops and when the gas flow falls below the minimum

The gas can be supplied through a gas distribution system or canisters.

Buffer gas ON

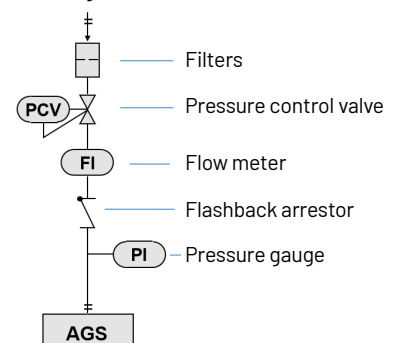

EagleBurgmann – at the leading edge of industrial sealing technology

Our products are used wherever safety and reliability count: in the industries of oil & gas, refineries, petrochemicals, chemicals, pharmaceuticals, food, power, water and many more. About 6,000 employees contribute their ideas, solutions and dedication every day to ensure that customers around the globe can rely on our seals. With our modular TotalSealCare Service, we emphasize our strong customer orientation and offer custom-tailored services for every need. [Rely on excellence.](#)

Wherever you need us

Europe • Austria • Belarus • Belgium • Bosnia-Herzegovina • Bulgaria • Cyprus • Czech Republic • Denmark • Estonia • Finland • France • Germany • Great Britain • Greece • Hungary • Ireland • Italy • Latvia • Lithuania • Netherlands • Norway • Poland • Portugal • Romania • Russia • Serbia • Slovak Republic • Slovenia • Spain • Sweden • Switzerland • Turkey • **Middle East** • Bahrain • Israel • Jordan • Kuwait • Lebanon • Oman • Qatar • Saudi Arabia • United Arab Emirates • Yemen • **Africa** • Angola • Botswana • Cameroon • Egypt • Gabon • Ghana • Kenya • Madagascar • Malawi • Mauritius • Mozambique • Namibia • Nigeria • South Africa • Sudan • Tunisia • Uganda • Zambia • Zimbabwe • **Americas** • Argentina • Brazil • Canada • Chile • Colombia • Ecuador • Mexico • Paraguay • Uruguay • United States • Venezuela • **Asia-Pacific** • Australia • Azerbaijan • Bangladesh • China • India • Indonesia • Japan • Kazakhstan • Korea • Malaysia • New Zealand • Pakistan • Philippines • Singapore • Sri Lanka • Taiwan • Thailand • Vietnam • www.eagleburgmann.com/en/international